



# Industri- og gaffeltruckdæk



**Produktoversigt  
og prislister  
nr. 25/Marts 2009**

**Skandinavisk  
Dæk Import A/S**



**70 128 128**

**[www.sdi.dk](http://www.sdi.dk)**



# Indhold

<b>Luftgummidæk</b> .....	<b>side 4</b>
Premium / Standard	
<b>Massivdæk</b> .....	<b>side 5</b>
Premium / Standard	
<b>Entreprenørdæk</b> .....	<b>side 6-7</b>
Mobilkran / Containertruck / Rendegraver	
Dumper / MPT dæk	
Minidozerdæk SKS / SKZ	
<b>Hjulbandager</b> .....	<b>side 8</b>
Cylindrisk ståring	
<b>Easybreaker</b> .....	<b>side 9</b>
Dækpresse (luftdæk)	
<b>Gafler</b> .....	<b>side 10-11</b>
<b>Fyldestof</b> .....	<b>side 12</b>
Tyrfil	
<b>Larvebånd</b> .....	<b>side 13</b>
<b>Fælg</b> .....	<b>side 14</b>
Gaffeltruckfælg/tilbehør	
Delbare fælg	
Drop-center-fælg	
<b>Sværlasthjul</b> .....	<b>side 15</b>
Vulkollan	
Antistatisk	
Polyurethane	
Palleruller	
Nylon	
<b>Lastvognsfælg</b> .....	<b>side 16-17</b>
<b>Lufttrykstabel</b> .....	<b>side 18</b>
For gaffeltruck dæk	
<b>Belastningstabel</b> .....	<b>side 19</b>
Minidozerdæk SKS / SKZ	
Lufttryk, Specifikation	
<b>Belastningstabel</b> .....	<b>side 20</b>
Luftgummidæk, Specifikation	
<b>Belastningstabel</b> .....	<b>side 21</b>
Massivdæk, Specifikation	
<b>Belastningstabel</b> .....	<b>side 22</b>
Hjulbandager, Specifikation	
<b>Generelt</b> .....	<b>side 23</b>
Leveringsbetingelser	



# Luftgummidæk

Luftgummidæk Premium / Standard

Dim:	Pr	Hauler LT	Pr	Ecomatic	Slange
400 x 8 RIB			6	556	81
400 x 8			10	687	
500 x 8	10	878	8	507	92
16 x 6 x 8	16	1.412			92
18 x 7 x 8	16	1.657	14	927	114
600 x 9	10	1.385	10	818	114
21 x 8 x 9	16	2.207	14	1.292	125
650 x 10	10	1.646	10	948	114
650 x 10	12	1.668			
750 x 10			12	1.482	152
23 x 9 x 10	20	2.856	18	2.267	179
700 x 12	14	2.185	14	1.158	136
23 x 10 x 12			14	2.322	222
27 x 10 x 12	16	3.902	20	3.352	195
27 x 10 x 12	24	4.520			
825 x 12			12	2.442	141
23 x 5 x 13			10	1.809	195
700 x 15	14	3.134	14	1.984	173
750 x 15	14	3.428	14	2.065	179
28 x 9 x 15	14	3.548	14	2.219	217
250 x 15	16	4.764	16	3.090	200
250 x 15	20	4.082	20	3.445	200
825 x 15	14	4.060	14	2.448	217
28 x 12.5 x 15	24	5.679			439
300 x 15			18	4.507	254
300 x 15	20	6.338			
32 x 12.1 x 15	24	8.535			271
750 x 16			12	2.628	271
825 x 20			14	2.960	315
900 x 20			14	3.477	315
1000 x 20	16	8.543	16	4.121	347
1100 x 20	18	9.571	18	4.507	380
1200 x 20	20	10.425	16	6.009	451
1200 x 20 PM	20	12.420			
1200 x 24 *			18	6.181	Ring om pris
1400 x 24 *	28	16.317	24	8.627	Ring om pris



Hauler LT



Ecomatic



Hvide  
Ecomatic / Hauler  
Luftgummidæk

\*) Andet fabrikat.

Tillæg: Grå dæk (Non marking) + 65%.



# Massivdæk

Magnum



Ecomatic



Hvid  
Massiv



Quick/  
Loc

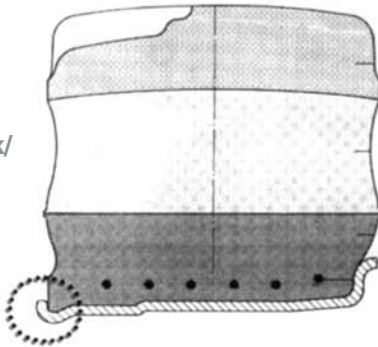

Dim.	Fælg	Magnum	Ecomatic
300 x 4	2.10	829	
300 x 4	2.50	894	
400 x 4 MIL	2.10	1009	
400 x 4 MIL	2.50	1025	
14 x 8 x 6	6.00	3.374	
400 x 8	3.00	1.467	1.139
15 x 4½ x 8	3.00	1.642	1.412
16 x 6 x 8	4.33	2.180	1.951
18 x 7 x 8	4.33	2.295	2.060
500 x 8	3.00	1.821	1.608
600 x 9	4.00	2.665	2.448
21 x 8 x 9	6.00	3.940	3.445
650 x 10	5.00	3.603	3.346
200/50 x 10	6.50	3.063	
23 x 9 x 10	6.50	4.889	4.572
700 x 12	5.00	4.529	3.995
23 x 10 x 12	8.00	6.175	
27 x 10 x 12	8.00	7.123	6.682
700 x 15	5.50	6.371	
750 x 15	6.50	6.818	
825 x 15	6.50	8.437	8.122
28 x 9 x 15	7.00	6.557	5.935
250 x 15	7.00	7.335	6.311
250 x 15	7.50	7.723	
28 x 12.5 x 15	9.75	9.647	7.979
300 x 15	8.00	11.063	8.752
355/65 x 15	9.75	12.867	11.336
900 x 20	6.50	12.480	
1000 x 20	7.50	14.791	12.867
1000 x 20	8.00	14.927	13.003
1200 x 20	8.00	21.745	
1200 x 24	8.50	Ring om pris	
1400 x 24	10.00		

Tillæg: Quick / loc + 5%

Tillæg: Grå / Non marking + 30%

Tillæg: Antistatic + 15%

Massivdæk Premium / Standard



# Entreprenør dæk

Mobilkran / Containertruck / Rendegraver / Dumpper / MPT dæk

Dim:		Pr	Type	Mønster	Solideal	Slange
11L x 15 SL	TL	10	IMPLEMENT	MR F3	1.816	
10.0 / 75 x 15.3	TL	8	DUMPER	4L R4	1.914	
11.5 / 80 x 15.3	TL	10	DUMPER	4L R4	2.713	
11L x 16 SL	TL	12	IMPLEMENT	MR F3	2.001	
14.5/75 x 16.1	TL	10	IMPLEMENT	MR F3	3.435	
10.5 / 80 x 18	TL	10	IMPLEMENT	SL R4	3.384	
10.5 x 18	TL	10	MPT	4L I3	2.876	
12.5 / 80 x 18	TL	12	IMPLEMENT	SL R4	3.430	
12.5 x 18	TL	12	MPT LUG	4L I3	4.014	
18 x 19.5	TL	20	MPT TM	4L R1	** Ring om pris	
10.5 x 20	TL	10	MPT	4L I3	3.164	
12.5 x 20	TL	12	MPT	4L I3	4.408	
14.5 x 20	TL	14	MPT	4L I3	5.077	
8.25 x 20	TT	12	KRAN	WL	3.381	312
9.00 x 20	TT	14	KRAN	WL	3.555	312
10.00 x 20	TT	16	KRAN	WL	3.751	345
11.00 x 20	TT	16	KRAN	WL	4.121	378
405 / 70 x 20 (16 / 70 x 20)	TL	14	MPT	4L I3	5.338	
18 x 22.5	TL	16	MPT	4LR1	** Ring om pris	
405 / 70 x 24 (16 / 70 x 24)	TL	14	MPT	4L I3	5.909	
14.9 x 24	TL	8	INDUSTRI	SL R4	5.909	
15.5/80 x 24	TL	14	INDUSTRI	SL R1	6.001	
16.5/80 x 24	TL	8	INDUSTRI	SL R1	5.245	
16.5/85 x 24	TL	16	MPT	4LR1	6.382	
16.9 x 24	TL	12	INDUSTRI	SL R4	6.778	
17.5L x 24	TL	12	INDUSTRI	SL R4	6.963	
19.5L x 24	TL	12	INDUSTRI	SL R4	8.170	
21L x 24	TL	12	INDUSTRI	SL R4	9.176	
15.5 x 25	TL	12	INDUSTRI	SL L2	7.235	
17.5 x 25	TL	16	INDUSTRI	SL L3	9.208	
20.5 x 25	TL	20	INDUSTRI	L3 G3 E3	13.323	
1600 x 25*	TL	28	INDUSTRI		** Ring om pris	
1800 x 25*	TL	40	INDUSTRI		** Ring om pris	
23.5 x 25	TL	24	INDUSTRI	LM L3	** Ring om pris	
26.5 x 25	TL	28	INDUSTRI	LM L3	** Ring om pris	
18.4 x 26	TL	12	INDUSTRI	SL R4	7.893	
16.9 x 28	TL	12	INDUSTRI	SL R4	7.694	
18.4 x 28	TL	12	INDUSTRI	SL R4	8.480	



MPT / dumper



Solideal  
Mobilkran dæk / WL



Solideal  
SLR4



Solideal  
MRF3



Solideal  
Tractionmaster  
SKSR1



# Entreprenør dæk



**Hauler SKS**  
Heavy-Duty/  
Ekstra forstærket



**Hauler SKZ**  
Lifemaster

Dim:	Pr	Hauler SKS	Pr	Hauler SKZ Lifemaster	Pr	Ecomatic SKS	Slange
570 x 12	6	1.107			6	899	108
23 x 8.5 x 12	6	1.167			6	1.009	188
23 x 8.5 x 12	12	1.352					
26 x 12 x 12					10	1.755	
27 x 10 x 12					14	2.556	
27 x 8.5 x 15	6	1.570			6	1.434	197
27 x 9.5 x 15	6	1.597					
27 x 10.5 x 15	8	1.619					
700 x 15					6	1.636	
31 x 15.5 x 15	8	3.662					
10 x 16.5	8	2.060			8	1.728	234
10 x 16.5	10	2.342	8	2.365	8	1.799	
12 x 16.5	10	3.265	10	3.750	10	2.704	300
31.5 x 13 x 16.5	10	3.146					
33 x 15.5 x 16.5	14	4.006	14	4.611			
14 x 17.5	14	4.877	14	5.613			
15 x 19.5	14	5.548					
380/65 x 19.5	14	5.357					
385/65 x 22.5	20	10.954					

Minidozerdæk SKS / SKZ

Er der størrelser, som du ikke finder i listen,  
så ring til ekspeditionen på tlf. +45 70 128 128

SL = Super Lug  
 WL = Wide Lug  
 MR = Multi Rib  
 LM = Load Master  
 TM = Traction Master  
 SM = Smooth  
 TR = Traction



# Hjulbandager

Hjulbandager cylindrisk stålrिंग

Dim. i tom.	Mø:	Adtrak
9 x 5 x 5	SM	704
10 x 4 x 6¼	SM	718
10 x 5 x 6¼	SM	741
10½ x 5 x 5	SM	1.543
10½ x 5 x 6½	SM	943
10½ x 6 x 6½	SM	1.074
13 x 3½ x 8	TR	1.074
13 x 4½ x 8	TR / SM	1.499
13 x 5 x 8	TR	1.706
13½ x 4½ x 8	TR / SM	1.668
13½ x 5½ x 8	TR	1.706
14 x 4½ x 8	TR / SM	1.799
14 x 5 x 10	SM	1.695
15½ x 5 x 10	TR	1.984
16 x 5 x 10½	TR / SM	1.924
16 x 6 x 10½	TR / SM	2.289
16 x 7 x 10½	TR / SM	2.529
15 x 5 x 11¼	TR / SM	1.684
16¼ x 5 x 11¼	TR / SM	2.148
16¼ x 6 x 11¼	TR / SM	2.235
16¼ x 7 x 11¼	TR / SM	2.343
17 x 5 x 121/8	TR / SM	1.924
18 x 5x 121/8	TR / SM	2.185
18 x 6 x 121/8	TR / SM	2.562
18 x 7 x 121/8	TR / SM	3.063
18 x 8 x 121/8	TR / SM	3.346
18 x 9 x 121/8	TR / SM	3.597
21 x 5 x 15	TR / SM	2.955
21 x 6 x 15	TR / SM	3.325
21 x 7 x 15	TR / SM	3.565
21 x 8 x 15	TR / SM	4.065
21 x 9 x 15	TR / SM	4.328
22 x 6 x 16	TR / SM	3.439
22 x 7 x 16	TR / SM	3.799
22 x 8 x 16	TR / SM	4.447
22 x 9 x 16	TR / SM	4.835
22 x 10 x 16	TR / SM	5.270
22 x 12 x 16	SM	5.974
28 x 12 x 22	TR / SM	8.208

Dim. i M.M.	Mønster:	Adtrak
250 x 130 x 140	SM	1.472
250 x 80 x 170	SM	851
250 x 105 x 170	SM	1.156
350 x 90 x 280	SM	1.221
415 x 75 x 305	SM	1.721
415 x 90 x 305	SM	1.858
415 x 100 x 305	SM	2.038
405 x 130 x 305	SM	1.794
405 x 260 x 305	SM	3.090
425 x 150 x 305	SM	2.153
425 x 260 x 305	SM	3.216
425 x 300 x 305	SM	4.251
450 x 260 x 305	SM	3.608
450 x 300 x 305	SM	3.995
520 x 120 x 370	SM	1.798
550 x 160 x 410	SM	2.311
645 x 300 x 410	SM	7.079
660 x 203 x 480	TR	7.145
660 x 250 x 480	TR	7.335

\*) Andet fabrikat.

Tillæg: Grå / Non marking + 40%

Tillæg: Antistatic + 15%

SM = Smooth

TR = Traction



Solideal Adtrak  
Glat



Solideal Adtrak  
Mønster





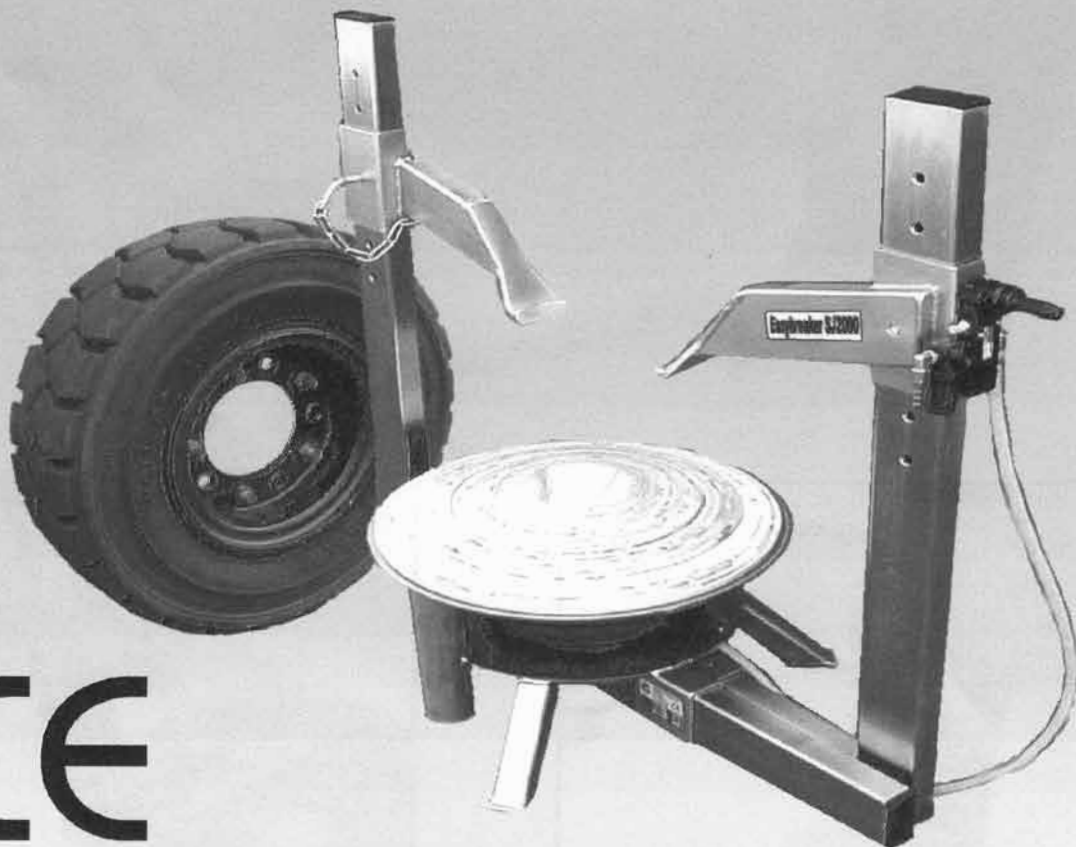

Easybreaker

# Easybreaker SJ2000



CE

**SLUT MED FORHAMMER OG DÆKMEJSEL.**

-  Hurtig og præcis afmontering af gaffeltruckdæk.
-  Kompakt, enkelt og driftssikker.
-  Udviklet for at opfylde nutiden og fremtidens krav.
-  Anvendelig både på værkstedet og fra servicevogn.

Ring om pris!

**Skandinavisk Dæk Import A/S**

Industrivænget 14 . 4622 Havdrup

Tlf. +45 70 128 128

Fax +45 46 185 141

E-mail: [sdi@sdi.dk](mailto:sdi@sdi.dk)





# Gafler

Gafler

Standard ITA/FEM mål					
Klasse	Type	E	H2	H1	B
I/1	A	76	306	394	331
	B	114		432	
II/2	A	76	382	470	407
	B	152		546	
III/3	A	76	477	568	508
	B	203		695	
IV/4	A	127	598	743	635
	B	254		870	
V/5	A	127	680	830	728
	B	257		960	

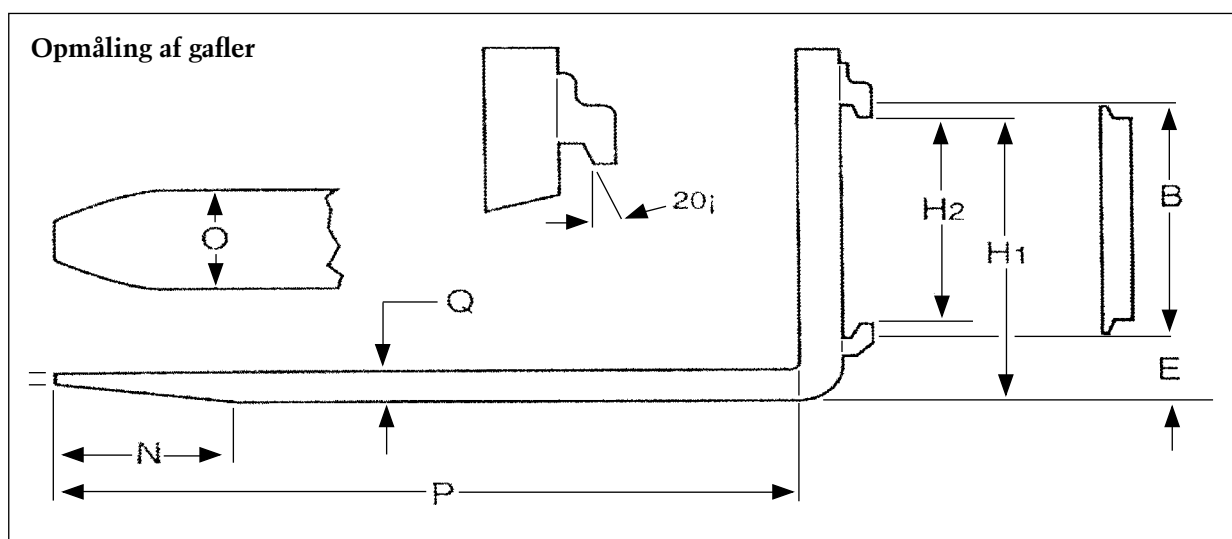

B	=	
E	=	
H1	=	
H2	=	
M	=	
N	=	
O	=	
P	=	
Q	=	

Alle gafler leveres i styrke og længde med spidser som følger den officielle 98/37 EEC standard.

Standard gafler leveres komplet med "hooks" og låse iflg. FEM standard.

Gafler med større løfte kapacitet, "blanks" og specielle gafler fremstilles efter opgave.

Indhent venligst tilbud.

Ved opmåling af gafler, notér venligst målene som anvist i skemaet.

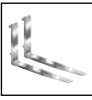

# Gafler

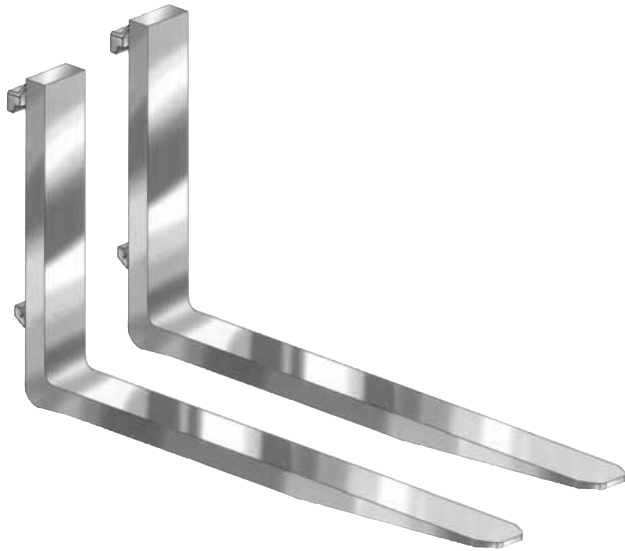

Gafler

Størrelse i mm.	Type	Lastevne pr. sæt
<b>80 x 40</b>		
1000	2A	2400/500
1100	2A	2400/500
1150	2A	2400/500
1200	2A	2400/500
1400	2A	2400/500
1500	2A	2400/500
1600	2A	2400/500
<b>100 x 40</b>		
800	2A	3000/500
900	2A	3000/500
1000	2A	3000/500
1100	2A	3000/500
1150	2A	3000/500
1200	2A	3000/500
1200	2B	3000/500
1300	2A	3000/500
1400	2A	3000/500
1400	2B	3000/500
1500	2A	3000/500
1600	2A	3000/500
1800	2A	3000/500
<b>120 x 40</b>		
1200	2A	3600/500
1200	2B	3600/500
<b>120 x 50</b>		
1200	3A	2800/500

Størrelse i mm.	Type	Lastevne pr. sæt
<b>125 x 40</b>		
1000	2A	3700/500
1200	2A	3700/500
1200	3A	3700/500
1450	2A	3700/500
1500	2A	3700/500
<b>125 x 45</b>		
1000	3A	4700/500
1100	3A	4700/500
1200	2A	4700/500
1200	3A	4700/500
<b>125 x 45</b>		
1400	3A	4700/500
1500	3A	4700/500
1600	2A	4700/500
1600	3A	4700/500
1800	3A	4700/500
<b>125 x 50</b>		
1200	3A	5900/500
1200	2B	5900/500
1200	3B	5900/500
1600	2A	5900/500
1600	3A	5900/500
2400	3A	5900/500
<b>150 x 50</b>		
1200	3A	7000/500
1200	3B	7000/500
1300	3B	7000/500
2000	3A	7000/500
2500	3B	7000/500

SDI lagerfører ca. 300 gafler.  
Ring om pris.



# Fyldestof

Tyrfil

	Dækdimension	Kg.		Dækdimension	Kg.
<b>4"</b>	250/280 x 4-2,25	2	<b>15"</b>	8,25 x 15-6,50	67
	3,00 x 4-2,25	3		10,00 x 15-8,00	93
	4,00 x 4-3,25	4		27x8,50 x 15-7,00	40
	4,10/3,50 x 4-3,25	4		28 x 12,5 x 12-9,75	52
	4,80/4,00 x 4-3,75	6		32 x 12,1 x 15-9,75	76
	9-3,50 x 4-3,75	4		250 x 15-7,00	45
<b>5"</b>	3,40/3,00 x 5-2,75	3		300 x 15-8,00	70
	3,50/3,00 x 5-2,75	3		355/65 x 15-9,75	76
<b>6"</b>	4,10/3,50 x 6-3,25	5		355/65 x 15-11,00	86
	4,00 x 6-3,25	7		<b>16,5"</b>	10 x 16,5-8,25
	4,10/4,50 x 6-3,25	7	12 x 16,5-9,75		84
<b>8"</b>	5,30/4,50 x 6-4,25	10	<b>20"</b>	7,50 x 20-6,00	70
	4,00 x 8-3,00	7		8,25 x 20-6,50	85
	15 x 4½ x 8-4,33	7		9,00 x 20-7,00	105
	16 x 6 x 8-4,33	10		10,00 x 20-7,50	130
	5,00 x 8-3,00	12		10,00 x 20-8,00	135
	18 x 7 x 8-4,33	15		11,00 x 20-8,00	148
<b>9"</b>	18 x 9 x 8-7,00	20	12,00 x 20-8,50	175	
	6,00 x 9-4,00	18	14,00 x 20-10,00	290	
	21 x 8 x 9-6,00	23	16,00 x 20-11,25	348	
<b>10"</b>	6,50 x 10-5,00	26	<b>24"</b>	11,00 x 24-8,00	167
	7,50 x 10-5,50	35		12,00 x 24-8,50	197
	21 x 8 x 10-5,50	23		14,00 x 24-10,00	321
	23 x 9 x 10-6,50	30		16,00 x 24-10,00	398
<b>12"</b>	570 x 12-4,50	17		18,00 x 24-13,00	527
	7,00 x 12-5,00	36		<b>25"</b>	17,5 x 25-14,00
	23 x 8,50 x 12-7,00	33	20,5 x 25-17,00		490
	23 x 10 x 12-8,00	39	23,5 x 25-19,50		673
27 x 10 x 12-8,00	48	26,5 x 25-22,00	874		
29,5 x 25-25,00	1157	<b>30"</b>	14,9 x 30-13,00		300
28 x 9 x 15-7,00	45		16,9 x 30-15,00	402	
<b>13"</b>	7,00 x 15-5,50 ind.	33	<b>33"</b>	65/35 x 33-28,00	1454
	7,00 x 15-6,00 øvr.	45			
	7,50 x 15-5,50	58			
	7,50 x 15-6,50	60			

## Tyrfil:

Polyurethan fyldestof.  
Ring om pris!!!

Undgå punktering.  
Lad os fylde dine dæk med Tyrfil Polyurethane, så har du robuste, punkterfrie dæk - massive - men med den samme bløde komfort som luftgummidæk.

Tyrfil kan benyttes til mange forskellige køretøjer, hvor punktering og driftstop er et problem. Maksimumhastighed 65 km/t.

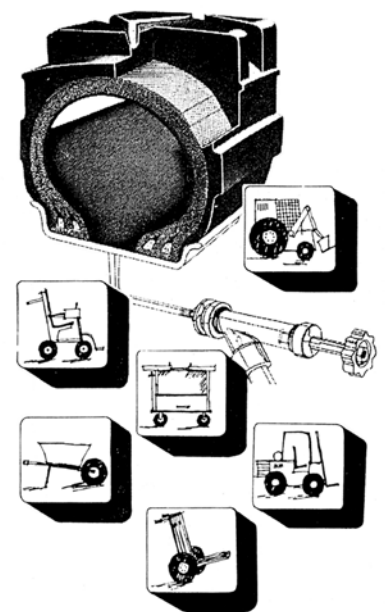

De angivne vægte er omtrentlige og kan variere med dækfabrikat og fælgbredde.



# Larvebånd

Solideal producerer gummibånd til næsten alle maskiner på markedet, i bredder fra 130 mm til 800 mm i mange forskellige mønstre, som alle er konstrueret til at give maksimal trækraft med et minimum af vibrationer og minimalt fladetryk.

Gummi båndnene produceres i to typer, „Conventional“ (traditionelle) og „Interchangeble“ (ombyttelige). Conventional er „long pitch“ med lang afstand mellem ledene i båndet, hvor kun hver anden tand på trækhjulet går i indgreb, og Interchangeble „Short pitch“ med kort afstand mellem ledene, her går alle tænderne på trækhjulet i indgreb.

Flere og flere maskinproducenter går over til „Short pitch“ bånd der har dobbelt så mange led som „Long pitch“. „Short pitch“ giver bedre økonomi og komfort, flere drifttimer, færre vibrationer, mindre støj og mindre fladetryk.

SDI lagerfører ca. 200 gummibånd i omkring 50 forskellige varenumre, hvilket dækker ca. 90% af det danske marked. Der kommer hele tiden nye maskiner med nye typer gummibånd på markedet.

Vi modtager løbende opdaterede lister som dækker tæt på 99% af de maskiner der kører på gummibånd, derfor kan vi, med få oplysninger fra dig, hurtigt finde frem til det rigtige.

**De vigtigste oplysninger for vores ekspedition er maskinens navn og model. Ud fra disse oplysninger kan vi klare næsten alle opgaverne, vi har dog set eksempler på at maskinproducenter har skiftet typen af undervognen uden at ændre maskinens modelbetegnelse. Dette er sjældent, men i disse tilfælde er maskinens serienummer og årgang vigtige oplysninger, så du får det rigtige bånd første gang.**

## Eksempel på betegnelse og opmåling

**Dimension: 230 x 43 x 72 AAP**

230 Bånd bredde (mm)

43 Antal led

72 Afstanden fra midt til midt af led (mm)

A: Mønster type

A: Type styre hjul

P: Type stålemne, indstøbt i båndet

**Båndets totale længde er antallet af led x afstanden fra et led til midten af det næste.**

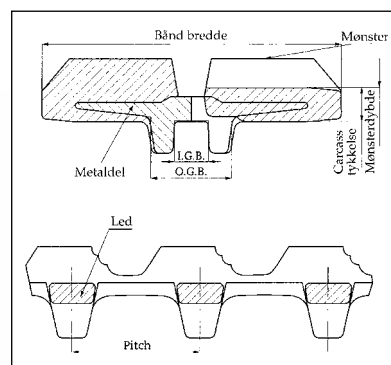

Ring om pris.





# Fælge

Gaffeltruckfælge / tilbehør

Fælg	Dæk	Fælg Komplet	Sidering	Låsering	Kilering
3.00D x 8	400/500 x 8 15 x 4½ x 8	2.485	355	311	273
4.33 x 8	16 x 6 x 8 18 x 7 x 8	2.616	409	333	
4.00E x 9	600 x 9	2.932	365	355	273
6.00E x 9	21 x 8 x 9	3.035	365	355	273
5.00F x 10	650 x 10	3.204	534	404	365
6.50F x 10	23 x 9 x 10	3.831	534	404	365
5.00S x 12	700 x 12	3.565	600	512	382
8.00G x 12	23 x 10 x 12 27 x 10 x 12	4.377	546	507	409
5.50 x 15	700/750 x 15	4.338	611	540	502
6.00 x 15	700/750 x 15	4.338	611	540	502
6.50 x 15	750/825 x 15	4.338	611	540	502
7.00 x 15	28 x 9/250 x 15	4.387	731	540	502
7.50 x 15	250 x 15	4.801	677	594	502
8.00 x 15	300 x 15	5.276	785	594	502
9.75 x 15	28 x 12.5/355 x 15	5.962	731	570	502
20"	Ring om pris				
24"	Ring om pris				
25"	Ring om pris				

Fælge leveres uden ringe for quick / loc dæk -10% rabat.

Tillæg:  
Tvilling fælg type D (hvelvet plade) kr. 653,-

Tillæg:  
Tvilling fælg type SD (ekstra højt offset) kr. 2064,-

Delbare fælge

Fælg dim.	Dæk dim.	Gods-tykkelse	Max. lufttryk	Pris
3.00 x 8	400/500 x 8	5 mm	7,5 bar	878
4.00 x 9	600 x 9	5 mm	7,0 bar	1.025
5.00 x 10	650 x 10	7 mm	10,0 bar	1.319
5.00 x 12	700 x 12	7 mm	10,0 bar	1.641

Låseringfælge Type D - SD



Låseringfælge Type N



Drop-center-fælge

Fælg dim.	Dæk dim.	Pris
5.00 x 12	570 x 12	2.122
7.00 x 12	23-8.5 x 12	2.726
7.00 x 15	27-8.5 x 15	3.177
9.00 x 15	10 x 15	3.177
8.25 x 16,5	10 x 16,5	3.177
9.75 x 16,5	12 x 16,5	3.428

Drop-center-fælge



Delbare fælge





# Sværlasthjul

**Vulkollan**



**Antistatisk**



**Polyurethane**



**Palleruller**



**Nylon**



Vulkollan / Antistatisk / Polyurethane / Palleruller / Nylon

Ring om pris.





# Lastvognsfølge



Følg 22.5x8.25																
15468	8	221	285	B19DS44	B5	BZ	151	165	42	152/148	L	9	A-C	12	truck	101126V
15355	10	220	285.75	M22	Ø 26	MZ	156	170	42	152/148	L	9	A	12	truck	285/60R22.5
15472	10	221.5	285.75	B19DS44.4	B5	BZ	156	170	42	152/148	M	9	A-C	12	truck	101126V
14420	10	281	335	M22	Ø 26	MZ	152	165	39.5	152/148	M	9	A	12	MAN	275/70R22.5
15388 ALV	10	281	335	M22	Ø 26	MZ	152	165	39.5	152/148	M	9	A	12	MAN	295/60R22.5
													B		Daimler	305/70R22.5
													A		Iveco	
13791	10	281	335	M22DS36	B33	UZ	152	165	39.5	152/148	M	9	A	12	truck	255/70R22.5
14908	10	281	335	M22	Ø 26	MZ	157	170	39.5	152/148	M	9	A	12	Iveco	275/60R22.5
12645	10	281	335	M23DC80	B37	UZ	157	170	39.5	152/148	M	9	A	12	truck	101126V
13527	10	281	335	M22DS36	B33	UZ	157	170	39.5	152/148	M	9	A	12/16	Iveco	11R22.5
																12R22.5
Følg 22.5x9.00																
15269	8	221	285	B19DS44	B5	BZ	161	175	45	156/150	M	9	A-C	12	truck	101126V
15263	10	221.5	285.75	B19DS44.4	B5	BZ	164	178	44.5	156/150	G	9	A-C	12	truck	101126V
15329	10	281	335	M22	Ø 26	MZ	161	175	42	156/150	M	9	A	12	Iveco	295/60R22.5
													A		MAN	305/60R22.5
													A		trailer	305/70R22.5
													A		RVI	315/60R22.5
15390 ALV	10	281	335	M22	Ø 26	MZ	161	175	41.5	156/150	M	9	A	12	MAN	315/70R22.5
													A		Iveco	315/75R22.5
													B		Daimler	315/60R22.5
													A		trailer	
12727	10	281	335	M23DC80	B37	UZ	161	175	42	156/150	M	9	A	12	truck	13R22.5
13794	10	281	335	M22DS36	B33	BZ	161	175	42	156/150	M	9	A	12	Iveco	295/60R22.5
Følg Med 15" Drop Center Wide Range																
Følg 22.5x11.75																
15373	10	281	335	M22	Ø 26	MZ	0	/	42.5	160	J	9	A	8/12	trailer	101144V
15326	10	281	335	M22DS36	B33	UZ	0	/	42.5	160	J	9	A	8/12	trailer	101144V
15776 ALV	10	281	335	M22	Ø 26	MZ	120	/	44	160	M	9	A	8/12	truck	385/65R22.5
15567 ALV	10	281	335	M23DC80	B37	UZ	120	/	44	160	M	9	A	8/12	truck	1390V
15609 ALV	10	281	335	M22	Ø 26	MZ	130	/	44	160	M	9	A	8/12	truck	365/70R22.5
15527	10	281	335	M22	Ø 26	MZ	-5	/	44	160	J	9	A	8/12	vendbar	1390V
																B102
Følg 22.5x13.00																
12358	10	281	335	M22DS36	B33	UZ	0	/	55	165	J	8.5	A	8	trailer	101144V
12532	10	281	335	M22	Ø 26	MZ	0	/	55	165	J	8.5	A	8	trailer	101144V
Følg 19.5x14.00																
15457	8	221	275	M22	Ø 26	MZ	0	/	39	160	J	9	A	8	trailer	425/55R19.5
15600	10	281	335	M22	Ø 26	MZ	0	/	39	160	J	9	A+B	8	trailer	435/50R19.5
																445/45R19.5
Følg 22.5x14.00																
12533	10	281	335	M22	Ø 26	MZ	0	/	60	168	J	9	A	8	trailer	101144V
12394	10	281	335	M22DS36	B33	UZ	0	/	60	168	J	9	A	8	trailer	445/65R22.5

Alle fælg leveres incl. ventiler, uden merpris.



# Luftrykstabel

For gaffeltruck dæk - max hastighed 35 km/t.

Dæk størrelse	Pr	Luftryk i BAR
500 x 8	8	8.00
500 x 8	10	10.00
18 x 7 x 8	14	9.00
18 x 7 x 8	16	10.00
18 x 7 x 8	18	10.00
600 x 9	10	8.5
600 x 9	12	10.00
21 x 8 x 9	14	9.50
21 x 8 x 9	16	10.00
650 x 10	10	8.00
650 x 10	12	9.00
650 x 10	14	10.00
23 x 9 x 10	18	9.00
23 x 9 x 10	20	10.00
700 x 12	12	8.00
700 x 12	14	9.00
700 x 12	16	10.00
23 x 10 x 12	14	9.00
23 x 10 x 12	16	9.50
27 x 10 x 12	14	9.00
27 x 10 x 12	16	9.50
27 x 10 x 12	20	10.00
27 x 10 x 12	24	10.00

Dæk størrelse	Pr	Luftryk i BAR
700 x 15	12	8.50
700 x 15	14	9.00
750 x 15	14	9.00
750 x 15	16	10.00
28 x 9 x 15	14	9.00
28 x 9 x 15	16	10.00
825 x 15	14	8.50
825 x 15	16	9.50
825 x 15	18	10.00
250 x 15	16	9.00
250 x 15	18	10.00
250 x 15	20	10.00
300 x 15	18	9.00
300 x 15	20	10.00
300 x 15	22	10.00
28 x 12.5 x 15	24	10.00
32 x 12.1 x 15	24	10.00
355 / 65 x 15	24	10.00
900 x 20	14	9.00
1000 x 20	14	9.00
1000 x 20	16	9.00
1200 x 20	16	9.00
1200 x 20	20	10.00

1 BAR = 14,7 psi

Alle radial dæk uanset dimension og fabrikat skal have et luftryk på 10 BAR. Kontroller luftrykket mindst hver anden uge. Det er ikke dækket, der bærer belastningen men luftrykket i dækket. Et for lavt luftryk er lig med overbelastning af dækket, som typisk giver skader i skuldre og kantråds partierne, samt et forøget energiforbrug og hurtigere slidtage.

### Eksempel:

20% for lavt luftryk nedsætter dækkets levetid med ca. 25%.

Det vil sige, at for hver 1000,- kr. dæk, mister du 250,- kr. grundet forkert luftryk.

### Vedr. delbare fælge

SDI A/S anbefaler følgende sikkerhedsprocedure ved dækskift, og advarer mod for højt luftryk i dæk på delbare fælge.

- Slip altid al luften ud af dækket før hjulet skrues af maskinen.
- Tjek altid samtlige bolte og møtrikker for brud og skader på gevind.
- Pump aldrig større tryk i dækket end 2,5 BAR før hjulet er korrekt monteret på maskinen igen.
- Overskrid aldrig det luftryk som garanteres af fælgens styrke.  
(kan varierer fra det ene fabrikat til det andet).
- Skift til låserings fælge hvis det anbefalede luftryk overstiger den delbare fælgs styrke.



# Belastingstabel

SIZE	PR.	RIM FITMENT <sup>1)</sup>		TYRE DIMENSIONS		INFLATION PRESSURE	LOAD CAPACITY <sup>3)</sup>			
				MAX IN SERVICE <sup>2)</sup>			STATIC <sup>5)</sup>	CREEP <sup>4)</sup>	8 KM/H	16 KM/H
				(+2%)						
		REC.	ALTER.	WIDTH	O.D.	BAR	KG.	KG.	KG.	KG.
				MM	MM					
23 x 8, 5-12	6	7,00	7,00JA	231	589	3,5	1080	950	825	650
26 x 12-12	10	10,50	8,50/8,50JA	307	648	4,5	2140	2070	1630	1290
27 x 8,5-15	6	7,00JA	6,50k	231	695	3,5	1350	1180	1030	810
27 x 10,5-15	8	8,50	8,00LB	259	695	4,1	1520	1330	1160	920
31 x 15,5-15	8	13,00	13,00LB	391	788	3,1	2210	1940	1690	1340
10-16,5	8	8,25		285	788	4,2	2460	2160	1875	1480
10-16,5	10	8,25		285	788	5,25	2800	2460	2120	1690
31,5 x 13-16,5	10	9,75		353	800	4,9	3190	2800	2435	1920
12-16,5	10	9,75		332	848	4,2	3180	2790	2430	1920
33 x 15,5-16,5	12	12,00		424	838	4,9	4130	3620	3150	2490
14-17,5	14	10,50		388	954	5,6	5080	4460	3875	3060
380/65-19,5	14	11,75	12,25	431	991	5,6	6640	5830	5070	4010
15-19,5	12	11,75	12,25	431	1056	4,2	5460	4800	4170	3290
15-19,5	14	11,75	12,25	431	1056	5,6	6640	5830	5070	4010

Minidozerdaek SKS / SKZ, Luftryk - Specification

## Remarks:

- 1) Consult tyre and wheelmanufacturer for confirmation of the suitability of the tyre/rim combination particularly with regard to rim profile, wheel strength and maximum inflation pressure.
- 2) The sizes given are according to ERTO or Tra, where available.  
For exact sizes, please consult the technical department.
- 3) For skid steer and mini-loader service.
- 4) Creep speed is a travel rate of not over 60 meters in a 30 minute period.
- 5) For higher static loads, please consult the technical department.



# Belastingstabel

Luchtgummidaek - Specificatie

TYRE SIZE	PR	TUBE	VALVE	FLAP	RIM (1)		TYRE DIMENSIONS MAX IN SERVICE (2)		LOAD CAPACITY (kg) (3) (4)						
					RECOMMEND	ALTERNATIVE	WIDTH	O.D. +/- 2%	FORKLIFTRUCKS UPTO 25 km/h		OTHER VEHICLES (5)				SIDE LOADERS STATIC 0 km/h
									LOAD WHEEL	STEER WHEEL	10 km/h	25 km/h	40 km/h	50 km/h	
5.00-8	10	5.00-8	JS2	5.00-8	3.00D	3.25I	143	476	1415	1090	1415	1090	970	915	1645
16X6-8	16	16X6-8	V3-02-05	18X7-8	4.33R		164	434	1580	1215	1580	1215	1080	1020	1835
18X7-8	8	18X7-8	V3-02-05	18X7-8	4.33R	5.0F	187	471	1415	1090	1415	1090	970	915	1645
18X7-8	10	18X7-8	V3-02-05	18X7-8	4.33R	5.0F	187	471	1625	1250	1625	1250	1115	1050	1890
18X7-8	14°	18X7-8	V3-02-05	18X7-8	4.33R	5.0F	187	471	1885	1450	1885	1450	1290	1220	2190
18X7-8	16	18X7-8	V3-02-05	18X7-8	4.33R	5.0F	187	471	2145	1650	2145	1650	1470	1385	2490
18X7-8	18	18X7-8	V3-02-05	18X7-8	4.33R	5.0F	187	471	2405	1850	2405	1850	1645	1555	2795
6.00-9	10	6.00-9	JS2	6.00-9	4.00E		173	551	1715	1320	1715	1320	1175	1110	1995
21X8-9	16	21X8-9	JS2	21X8-9	6.00E	7.00E	216	546	2755	2120	2755	2120	1885	1780	3200
6.50-10	10	6.50-10	JS2	6.50-10	5.00F	5.50F	191	600	1950	1500	1950	1500	1335	1260	2265
6.50-10	12	6.50-10	JS2	6.50-10	5.00F	5.50F	191	600	2145	1650	2145	1650	1470	1385	2490
23X9-10	18°	23X9-10	JS2	23X9-10	6.50F		243	607	3160	2430	3160	2430	2165	2040	3670
23X9-10	20	23X9-10	JS2	23X9-10	6.50F		243	607	3445	2650	3445	2650	2360	2225	4000
7.00-12	12	7.00-12	TR75A	7.00-12	5.00S		207	685	2680	2060	2680	2060	1835	1730	3110
7.00-12	14	7.00-12	TR75A	7.00-12	5.00S		207	685	2755	2120	2755	2120	1885	1780	3200
7.00-12	16	7.00-12	TR75A	7.00-12	5.00S		207	685	2910	2240	2910	2240	1995	1880	3380
23X10-12	16°	23X10-12	JS2	23X10/27X10-12	8.00G		282	632	3535	2720	3535	2720	2420	2285	4105
27X10-12	16°	27X10-12	JS2	23X10/27X10-12	8.00G		275	704	3900	3000	3900	3000	2670	2520	4530
27X10-12	24	27X10-12	JS2	23X10/27X10-12	8.00G		275	704	5525	4250	5525	4250	3785	3570	6420
7.00-15	14	7.00/7.50/8.25-15	TR75A	7.00/7.50/8.25-15	5.50	5.0	213	761	3350	2575	3350	2575	2290	2165	3890
7.50-15	14	7.00/7.50/8.25-15	TR75A	7.00/7.50/8.25-15	6.0	5.5/6.50	229	787	3640	2800	3640	2800	2490	2350	4230
8.25-15	14	8.25-15	TR77A	7.00/7.50/8.25-15	6.50	6.0/7.0	253	853	4225	3250	4225	3250	2895	2730	4910
8.25-15	16	8.25-15	TR77A	7.00/7.50/8.25-15	6.50	6.0/7.0	253	853	4615	3550	4615	3550	3160	2980	5360
28X9-15(8.15-15)	14	7.00/7.50/8.25-15	TR75A	8.15/250/300-15	7.0		233	721	3770	2900	3770	2900	2580	2435	4380
250-15	16	250-15	TR77A	8.15/250/300-15	7.50	7.0	270	750	4355	3350	4355	3350	2980	2815	5060
250-15	20	250-15	TR77A	8.15/250/300-15	7.50	7.0	270	750	5200	4000	5200	4000	3560	3360	6040
300-15	20	300-15	TR78A	8.15/250/300-15	8.0		324	857	6340	4875	6340	4875	4340	4095	7360
28X12.5-15	24	28X12.5-15	TR78A	28/32*12.1-15	9.75		338	751	6015	4625	6015	4625	4115	3885	6985
32X12.1-15	24	32X12.1-15	TR78A	28/32*12.1-15	9.75		338	879	7800	6000	7800	6000	5340	5040	9060
35X15-15(14.50-15)	16°				10.50	11.00	409	961	6535	5025	6535	5025	4470	4220	7590
35X15-15(14.50-15)	28°				10.50	11.00/11.50	409	961	8055	6195	8055	6195	5515	5205	9355
36X11-15(10.00-15)	16°				7.50	8.0	309	978	5200	4000	5200	4000	3560	3360	6040
9.00-20	14°				7.0	6.50/7.50	279	1038	5340	4450	5340	4450	3960	3740	6720
9.00-20	16°				7.0	6.50/7.50	279	1038	5700	4750	5700	4750	4230	3990	7175
10.00-20	16	10.00-20	V3-02-14	10.00/12.00-20	7.50	7.0/8.0	297	1073	6000	5000	6000	5000	4450	4200	7550
12.00-20	20	12.00-20	V3-02-14	10.00/12.00-20	8.50	8.0/9.0	338	1144	8220	6850	8220	6850	6095	5755	10345

## REMARKS

- Consult tyre and wheturer for confirmation of the suitability of the tyre/rim combination particulegard to rim profile and wheel strength.
- The sizes given are do ETRTO, where available.  
For exact sizes, please the technical department.
- The speed specified ks is the unloaded lifttruck's maximum speed capability.  
An increase of the loies is not permitted even in the case of lower speeds.
- This category include:
  - drive and steer wheel than counterbalanced forkliftrucks
  - wheels on mobile c
  - free rolling wheels ; up to a maximum distance of 2000 m per journey
  - For longer distancels fitted to rotary plants and for straddle carrier applications, please contact the department.



# Belastingstabel

Massivdaek - Specification

TYRE SIZE	RIM (1) SIZE	BASE TYPE QUICK	TYRE DIMENSION IN mm (3)		LOAD CAPACITY (kg) (2)					
			MAX. WIDTH	O.D. ± 2%	FORKLIFTRUCKS		OTHER VEHICLES (4)			STATIC 0 km/h
					LOAD WHEEL	STEER WHEEL	6 km/h	10 km/h	25 km/h	
3.00 - 4	2.10 - 4		87	250	255	195	255	230	195	295
	2.50C - 4									
4.00 - 4	2.10 - 4		116	306	535	410	535	485	410	620
	2.50C - 4		116							
4.00 - 8	3.00D - 8	■	130	406	950	730	950	860	730	1100
5.00 - 8	3.00D - 8	■	143	458	1415	1090	1415	1285	1090	1645
	3.25I - 8									
15 x 4 1/2 - 8	3.00 D - 8	■	132	377	1040	800	1040	940	800	1210
	3.25I - 8									
16 x 6 - 8	4.33R - 8	■	164	417	1270	975	1270	1150	975	1470
18 x 7 - 8	4.33R - 8	■	187	453	2145	1650	2145	1945	1650	2490
5.00 - 9	3.50D - 9		129	487	1445	1110	1445	1310	1110	1675
6.00 - 9	4.00E - 9	■	173	529	1885	1450	1885	1710	1450	2190
21 x 8 - 9	6.00E - 9	■	216	524	2755	2120	2755	2505	2120	3200
6.50 - 10	5.00F - 10	■	191	576	2340	1800	2340	2125	1800	2720
7.50 - 10	5.00F - 10	■	224	632	3070	2360	3070	2785	2360	3565
	5.50F - 10	■	224							
23 x 9 - 10	6.50F - 10	■	243	583	3445	2650	3445	3125	2650	4000
200/50 - 10	6.50F - 10	■	200	457	2470	1900	2470	2240	1900	2870
7.00 - 12	5.00S - 12	■	207	657	2920	2240	2920	2645	2240	3380
8.25 - 12	5.00S - 12		210	724	3440	2645	3440	3120	2645	3995
23 x 10 - 12	8.00G - 12	■	275	583	3770	2900	3770	3420	2900	4380
27 x 10 - 12	8.00G - 12	■	275	676	3900	3000	3900	3540	3000	4530
150/100 - 13 (23x5)	3.75P - 13	□	167	622	1495	1150	1495	1355	1150	1735
6.00 - 15	4.50 - 15		165	700	2725	2095	2725	2470	2095	3165
7.00 - 15	5.50 - 15	■	213	731	3545	2725	3545	3215	2725	4115
7.50 - 15	5.50 - 15	■	229	757	3900	3000	3900	3540	3000	4530
	6.00 - 15	■								
	6.50 - 15	■	229	757						
8.25 - 15	5.50 - 15	■								
	6.00 - 15	■								
	6.50 - 15	■	253	819	4750	3650	4750	4300	3650	5510
28 x 9 - 15	7.00 - 15	■	233	693	3445	2650	3445	3125	2650	4000
250 - 15	7.00 - 15	■	265	720	4640	3570	4640	4200	3570	5390
	7.50 - 15									
300 - 15	8.00 - 15	■	324	823	5735	4410	5735	5210	4410	6660
28 x 12.5 - 15	9.75 - 15	■	318	693	5040	3875	5040	4575	3875	5850
355/65 - 15	9.75 - 15	■	355	823	7800	6000	7000	6430	5450	9060
10.00 - 20	6.50 - 20		287	1029	5840	4865	5840	5315	4865	7345
	7.00 - 20		292							
	7.50 - 20		297		6000	5000	6000	5450	5000	7550
	8.00 - 20		302							
12.00 - 20	8.00 - 20		332	1098	7500	6250	7500	6815	6250	9440
	8.50 - 20		337							
14.00 - 24	10.00 - 24		405	1313	11000	9175	11000	10000	9175	13855
14.00 - 25	11.25 - 25		405	1345	12500	10400	12500	11335	10400	15705

**REMARKS**

- (1) Check rim for size, especially on width, as this should correspond to tyre base marking. Check also max. load of rim with rim manufacturer, as wheel load will be restricted by lowest load capacity, either the one given by the rim or by the tyre.
- (2) The speeds quoted in the table are the maximum speeds of the unloaded vehicle. An increase in load capacity for lower speeds is not permitted. Loads are valid for intermittent service only, they do not include the additional weight of the tyres.
- (3) The sizes given are according to ETRTO, where available. Due to their construction and to ensure the interchangeability with pneumatic tyres, the solid tyre may be substantially smaller than the overall width in service of the equivalent pneumatic.  
For more accurate information please contact the technical department.
- (4) This category includes:  
- drive and steer wheels on other than counterbalanced forkliftrucks - wheels on mobile cranes  
- free rolling wheels on trailers, up to a maximum distance of 2000m per journey.  
For longer distances, fitted to wheels for rotary plants and for straddle carrier applications please consult the technical department.



# Belastingstabel

Hjulbandager - Specifikation

Tyre Size (1)		Tread Design				Load capacity in daN (2)										
in inches	in mm					Counterbalanced Forklifttrucks						Other vehicles (3)				Ro/Ro
OD x W x ID	OD / W - ID	SM	ATL	LUG	RIB	10 km/h		16 km/h		25 km/h		6 km/h	10 km/h	16 km/h	25 km/h	Trailers (4)
						Load Wheel	Steer Wheel	Load Wheel	Steer Wheel	Load Wheel	Steer Wheel					
9 x 5 x 5	229/127 - 127.0	●				960	790	855	720	695	570	1030	755	685	515	1030
10 x 4 x 6 1/4	254/102 - 158.8	●				785	645	700	590	570	465	840	615	560	420	840
10 x 5 x 6 1/4	254/127 - 158.8	●				1025	845	915	770	745	610	1100	805	735	550	1100
10 x 6 x 6 1/4	254/152 - 158.8	●				1265	1040	1130	950	920	755	1360	995	905	680	1360
10 x 4 x 6 1/2	254/102 - 165.1	●				780	640	695	585	565	465	835	610	555	415	835
10 x 5 x 6 1/2	254/127 - 165.1	●				1015	835	905	760	735	605	1085	795	725	545	1085
10 1/2 x 5 x 6 1/2	267/127 - 165.1	●				1075	885	960	810	780	640	1155	845	770	575	1155
10 1/2 x 6 x 6 1/2	267/152 - 165.1	●				1335	1095	1190	1000	970	795	1430	1050	955	715	1430
13 x 3 1/2 x 8	330/89 - 203.2	●				870	715	775	645			1030	680	620	470	1030
13 x 4 1/2 x 8	330/114 - 203.2	●				1115	920	995	840	810	665	1195	880	800	600	1195
13 1/2 x 4 1/2 x 8	343/114 - 203.2	●	●			1145	940	1020	860	830	680	1225	900	820	615	1225
13 1/2 x 5 1/2 x 8	343/140 - 203.2	●				1510	1240	1350	1135	1095	900	1620	1185	1080	810	1620
14 x 4 1/2 x 8	356/114 - 203.2	●	●			1165	955	1040	875	845	695	1250	915	830	625	1250
14 x 5 x 10	356/127 - 254.0	●				1335	1100	1195	1000	970	795	1430	1050	955	715	1430
15 1/2 x 5 x 10	394/127 - 254.0	○	●			1475	1210	1315	1105	1070	875	1580	1155	1050	790	1580
15 1/2 x 6 x 10	394/152 - 254.0	○				1865	1530	1665	1395	1355	1110	1995	1465	1330	1000	1995
16 x 5 x 10 1/2	406/127 - 266.7	●	●			1505	1240	1345	1130	1095	895	1615	1185	1075	805	1615
16 x 6 x 10 1/2	406/152 - 266.7	●	●			1905	1565	1700	1430	1385	1135	2040	1495	1360	1020	2040
16 x 7 x 10 1/2	406/178 - 266.7	●	●			2320	1905	2070	1740	1685	1380	2485	1820	1655	1245	2485
15 x 5 x 11 1/4	381/127 - 285.8	●				1390	1145	1240	1045	1010	830	1490	1095	995	745	1490
15 x 6 x 11 1/4	381/152 - 285.8	●				1720	1410	1535	1290	1250	1025	1840	1350	1225	920	1840
16 1/4 x 5 x 11 1/4	413/127 - 285.8	●	●			1525	1250	1360	1145	1105	905	1635	1200	1090	815	1635
16 1/4 x 6 x 11 1/4	413/152 - 285.8	●	●			1915	1570	1710	1435	1390	1140	2050	1505	1365	1025	2050
16 1/4 x 7 x 11 1/4	413/178 - 285.8	●	●			2320	1905	2070	1740	1685	1380	2485	1820	1655	1245	2485
16 1/4 x 8 x 11 1/4	413/203 - 285.8	●	●			2710	2225	2420	2030	1965	1615	2905	2130	1935	1450	2905
17 x 5 x 12 1/8	432/127 - 308.0	●				1575	1295	1405	1180	1145	940	1690	1240	1125	845	1690
17 x 6 x 12 1/8	432/152 - 308.0	●				1975	1620	1765	1480	1435	1175	2115	1550	1410	1060	2115
18 x 5 x 12 1/8	457/127 - 308.0	●	●			1640	1350	1465	1230	1195	980	1760	1290	1175	880	1760
18 x 6 x 12 1/8	457/152 - 308.0	●	●			2090	1715	1865	1565	1515	1245	2240	1640	1490	1120	2240
18 x 7 x 12 1/8	457/178 - 308.0	●	●			2555	2100	2280	1915	1855	1520	2735	2005	1825	1370	2735
18 x 8 x 12 1/8	457/203 - 308.0	●	●			3000	2465	2680	2250	2180	1785	3215	2355	2145	1605	3215
18 x 9 x 12 1/8	457/229 - 308.0	●	●			3465	2845	3095	2600	2515	2060	3710	2720	2475	1855	3710
20 x 8 x 15	508/203 - 381.0	●				3165	2600	2825	2375	2295	1885	3390	2485	2260	1695	3390
20 x 9 x 15	508/229 - 381.0	●				3635	2985	3245	2725	2640	2165	3895	2855	2600	1950	3895
21 x 7 x 15	533/178 - 381.0	●	●			2870	2360	2565	2155	2085	1710	3075	2255	2050	1540	3075
21 x 8 x 15	533/203 - 381.0	●	●			3375	2775	3015	2530	2450	2010	3620	2655	2410	1810	3620
21 x 9 x 15	533/229 - 381.0	●	●			3900	3205	3485	2925	2835	2320	4180	3065	2785	2090	4180
20 x 8 x 16	508/203 - 406.4	●	●			3010	2470	2685	2255	2185	1790	3225	2365	2150	1610	3225
20 x 9 x 16	508/229 - 406.4	●	●			3445	2830	3075	2580	2500	2050	3690	2705	2460	1845	3690
22 x 6 x 16	559/152 - 406.4	●	●			2430	1995	2170	1825	1765	1445	2605	1910	1735	1300	2605
22 x 8 x 16	559/203 - 406.4	●	●			3500	2875	3125	2625	2540	2085	3750	2750	2500	1875	3750
22 x 9 x 16	559/229 - 406.4	●	●			4045	3325	3615	3035	2940	2410	4335	3180	2890	2170	4335
22 x 10 x 16	559/254 - 406.4	●	●			4570	3755	4080	3430	3320	2720	4895	3590	3265	2450	4895
22 x 12 x 16	559/305 - 406.4	●	●			5640	4635	5035	4230	4095	3355	6045	4430	4030	3020	6045
22 x 14 x 16	559/356 - 406.4	●	●			6710	5510	5990	5030	4875	3995	7190	5270	4795	3595	7190
22 x 16 x 16	559/406 - 406.4	●	●			7760	6375	6925	5820	5635	4620	8315	6095	5540	4155	8315
22 x 12 x 17 1/4	559/305 - 451.0	●		●		5155	4235	4600	3865	3740	3070	5520	4050	3680	2760	5520
28 x 10 x 22	711/254 - 559.0	○				5470	4495	4885	4105	3970	3255	5860	4300	3905	2930	5860
28 x 12 x 22	711/305 - 559.0	●		●		6750	5545	6025	5060	4900	4015	7230	5305	4820	3615	7230
28 x 14 x 22	711/356 - 559.0	○				8030	6695	7170	6020	5830	4780	8600	6310	5735	4300	8600
28 x 16 x 22	711/406 - 559.0	○				9280	7625	8290	6960	6740	5525	9945	7295	6630	4975	9945
250/130 - 140		○				1065	875	950	800	775	635	1140	835	760	570	1140
250/80 - 170		●				620	510	555	460			735	485	440	335	735
250/105 - 170		●				785	645	700	590	570	465	840	615	560	420	840
330/145 - 180		●		●		1540	1265	1375	1155	1115	915	1650	1210	1100	825	1650
330/145 - 194		●				1535	1260	1370	1150	1115	915	1645	1205	1095	820	1645
365/160 - 220		○				1880	1545	1680	1410	1365	1120	2015	1480	1345	1010	2015
380/165 - 246		●		●		2000	1645	1785	1500	1455	1190	2145	1575	1430	1070	2145
350/90 - 280		●				900	740	805	675			1070	705	645	485	1070
405/130 - 305		●				1510	1240	1350	1130	1095	900	1620	1185	1080	810	1620
405/260 - 305		●				3325	2730	2970	2495	2415	1980	3560	2610	2375	1780	3560
425/150 - 305		●				1910	1570	1705	1435	1390	1135	2045	1500	1365	1025	2045
425/260 - 305		●				3625	2975	3235	2720	2630	2155	3885	2845	2590	1940	3885
450/300 - 305		●				4650	3820	4150	3490	3375	2770	4980	3655	3320	2490	4980
520/120 - 370		●				1670	1370	1490	1255	1215	995	1790	1310	1195	895	1790
540/200 - 410		●				3270	2685	2920	2450	2375	1945	3500	2570	2335	1750	3500
550/120 - 410		●				1750	1440	1565	1315	1270	1040	1875	1375	1250	940	1875
550/160 - 410		●				2555	2095	2280	1915	1855	1520	2735	2005	1825	1370	2735
645/300 - 410		●				6060	4960	5275	4330	4250	3465	6300	4485	3935	3150	6300
660/203 - 480		●		●		3695	3025	3215	2640	2590	2110	3840	2735	2400	1920	3840
660/250 - 480		●		●		4785	3915	4160	3415	3355	2735	4970	3540	3105	2485	4970

- 0 STANDARD COMPOUND
- 2 NON MARKING COMPOUND
- 4 ANTISTATIC COMPOUND
- 5 ELECTRICALLY CONDUCTING COMPOUND

Remarks

- (1) Tolerances on wheel diameter  
inch sizes: nominal rim diameter + 0.005"/0"  
metric sizes: h 11 according to ISO/R286  
surface roughness Ra < 6.3 µm  
chamber 5 mm wide @ 30°

- (2) The speeds quoted in the table are the maximum speeds of the unladen vehicle. An increase in load capacity for lower speeds is not permitted.
- (3) This category includes: drive and steer wheels on other than counterbalanced forklifttrucks; wheels on mobile cranes; free rolling wheels on trailers, upto a maximum distance of 2000 m per journey. For longer distances and for wheels for rotary plants please consult the technical department.
- (4) Single trip applications. For Lo/Lo trailers values of category 'other vehicles' at appropriate speed should be taken.
- (5) In preparation.





# Generelt

## LEVERINGSBETINGELSER:

Fremsendelse af denne prisliste forpligter ikke til levering.

De opgivne priser kan ændres uden varsel.

Der tages forbehold for trykfejl.

Vi påtager os intet ansvar for skader og drift tab, der måtte påføres personer, selskaber eller genstande ved brug af de i denne prisliste nævnte produkter.

Prislisten annullerer alle tidligere fremsendte.

Alle leverancer fremsendes franko til alle land- og brofaste fi rmaadresser i Danmark.

Alle priser er ekskl. moms.

## RETURNERING AF VARER:

Varer tages kun retur efter aftale med vores ekspedition, fakturanummer bedes oplyst.

## OMKOSTNINGSTILLÆG OG GEBYRER:

Returnering af korrekt leverede varer skal ske franko, der beregnes 5% til dækning af omkostninger.

Miljø gebyr faktureres i fl g. gældende bestemmelser fra Miljøministeriet og Dækbranchens Miljøfond.

Ved varekøb under 1000,- nt. beregnes en fragtandel på pt. 100,- nt.

Til dækning af fragtmændenes "palleombytningsgebyr" faktureres for  $\frac{1}{4}$  -  $\frac{1}{2}$  eller  $\frac{1}{1}$  Europa palle pt. 8,- nt stk.

## REKLAMATIONSBETINGELSER:

Produkter, der skønnes behæftet med fabrikationsfejl sendes FRANKO til vor adresse, til undersøgelse.

Fejlen skal afmærkes på produktet, kopi af købsfaktura eller følgeseddel medsendes.

## UDOVER PRODUKTERNE I DENNE PRISLISTE FORHANDLER VI FØLGENDE:

Dæk, slanger, fyldestof, fælge, nav, og gummilarvebånd til entreprenør maskiner, park, landbrug og industri.

*Rekvirer venligst prislister og brochurer.*



# SDI

- altid din stærke partner!

**Skandinavisk  
Dæk Import A/S  
Industrivænget 14  
4622 Havdrup  
Fax 46 18 51 41**

**Jyllandsafdeling:  
Edwin Rahrsvej 82  
8220 Brabrand  
Fax 86 26 08 32**

**E-mail: [sdi@sdi.dk](mailto:sdi@sdi.dk)  
[www.sdi.dk](http://www.sdi.dk)**



**Telefon  
70 128 128**

**Skandinavisk  
Dæk Import A/S**